

Tiny House

Min. living 220' sq.
Min. bath 42' sq.
Min. kitchen 30' sq.
Separate closet 4'sq.

Minimum Dwelling size: 296'sq.
Maximum Dwelling Size 400' sq.

DWELLING UNIT. A single unit providing complete independent living facilities for one or more persons, including permanent provisions for living, sleeping, eating, cooking and sanitation.

SECTION R304 MINIMUM ROOM AREAS

R304.1 Minimum area.

Every dwelling unit shall have at least one habitable room that shall have not less than 120 square feet of gross floor area.

R304.2 Other rooms.

Other habitable rooms shall have a floor area of not less than 70 square feet.

Exception: Kitchens.

R304.3 Minimum dimensions.

Habitable rooms shall not be less than 7 feet in any horizontal dimension.

Exception: Kitchens.

R304.4 Height effect on room area.

Portions of a room with a sloping ceiling measuring less than 5 feet or a furred ceiling measuring less than 7 feet from the finished floor to the finished ceiling shall not be considered as contributing to the minimum required habitable area for that room.

SECTION R305 CEILING HEIGHT

R305.1 Minimum height. Habitable space, hallways, bathrooms, toilet rooms, laundry rooms and portions of basements containing these spaces shall have a ceiling height of not less than 7 feet

Exceptions:

1. For rooms with sloped ceilings, at least 50 percent of the required floor area of the room must have a ceiling height of at least 7 feet and no portion of the required floor area may have a ceiling height of less than 5 feet

2. Bathrooms shall have a minimum ceiling height of 6 feet 8 inches at the center of the front clearance area for fixtures as shown in Figure R307.1. The ceiling height above fixtures shall be such that the fixture is capable of being used for its intended purpose. A shower or tub equipped with a showerhead shall have a minimum ceiling height of 6 feet 8 inches above a minimum area 30 inches by 30 inches at the showerhead.

R305.1.1 Basements.

Portions of basements that do not contain habitable space, hallways, bathrooms, toilet rooms and laundry rooms shall have a ceiling height of not less than 6 feet 8.

Exception: Beams, girders, ducts or other obstructions may project to within 6 feet 4 inches) of the finished floor.

SECTION R306 SANITATION

R306.1 Toilet facilities.

Every dwelling unit shall be provided with a water closet, lavatory, and a bathtub or shower.

R306.2 Kitchen.

Each dwelling unit shall be provided with a kitchen area and every kitchen area shall be provided with a sink.

R306.3 Sewage disposal.

All plumbing fixtures shall be connected to a sanitary sewer or to an approved private sewage disposal system.

R306.4 Water supply to fixtures.

All plumbing fixtures shall be connected to an approved water supply. Kitchen sinks, lavatories, bathtubs, showers, bidets, laundry tubs and washing machine outlets shall be provided with hot and cold water.

SECTION R307

TOILET, BATH AND SHOWER SPACES

R307.1 Space required.

Fixtures shall be spaced in accordance with Figure R307.1, and in accordance with the requirements of Section P2705.1.

FIGURE R307.1 MINIMUM FIXTURE CLEARANCES

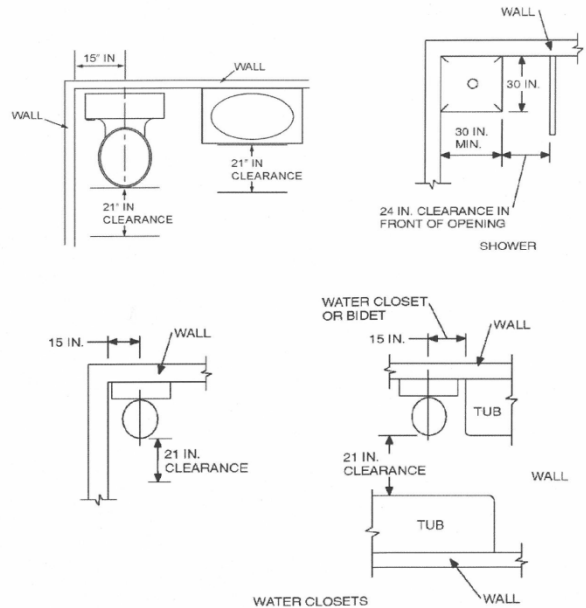

R307.2 Bathtub and shower spaces.

Bathtub and shower floors and walls above bathtubs with installed shower heads and in shower compartments shall be finished with a nonabsorbent surface. Such wall surfaces shall extend to a height of not less than 6 feet) above the floor.